

ABB BALDOR RELIANCE III

Customer information packet

JMFSWDM3559T-E

3HP, 3470RPM, 3PH, 60HZ, 145JM, 3546M, TEFC, F1

Class - None

Division - Not Applicable

Specifications

Enclosure	TEFC
Frame	145JM
Frame Material	Stainless Steel
Frequency	60.00 Hz
Haz Area Class and Group	None
Haz Area Division	Not Applicable
Motor Letter Type	Three Phase
Output @ Frequency	3.000 HP @ 60 HZ
Phase	3
Synchronous Speed @ Frequency	3600 RPM @ 60 HZ
Voltage @ Frequency	230.0 V @ 60 HZ 460.0 V @ 60 HZ
Agency Approvals	UR CSA
Ambient Temperature	40 °C
Auxiliary Box	NO AUXILLARY BOX
Auxiliary Box Lead Termination	None
Base Indicator	Rigid
Bearing Grease Type	Polyrex EM (-20F +300F)
Blower	None
Current @ Voltage	3.700 A @ 460.0 V 7.400 A @ 230.0 V 7.700 A @ 208.0 V
Design Code	A
Drip Cover	No Drip Cover
Duty Rating	CONT
Efficiency @ 100% Load	86.5 %
Electrically Isolated Bearing	Not Electrically Isolated
Feedback Device	NO FEEDBACK
Front Face Code	Standard
Front Shaft Indicator	None
Heater Indicator	No Heater

Part Detail

Revision	M
Type	AC
Mech. spec.	35E4781
Base	
Status	PRD/A
Elec. spec.	35WGR930
Layout	35LYE4781
Eff. date	08-14-2023
CD Diagram	CD0005
Poles	02
Leads	9#18,0#,0#,0# Y
Proprietary	False
Created date	11-07-2017

High Voltage Full Load Amps	3.7 a
Insulation Class	H
Inverter Code	Inverter Ready
KVA Code	P
Lifting Lugs	No Lifting Lugs
Locked Bearing Indicator	Locked Bearing
Motor Finish	UNPAINTED
Motor Lead Exit	Ko Box
Motor Lead Quantity/Wire Size	@ 0 AWG 9 @ 18 AWG
Motor Lead Termination	Flying Leads
Motor Standards	NEMA
Motor Type	3546M
Mounting Arrangement	F1
Number of Poles	2
Overall Length	18.40 IN
Power Factor	91
Product Family	WD All SS Encapsulated
Pulley End Bearing Type	Sealed Bearing
Pulley Face Code	C-Face
Pulley Shaft Indicator	Tapped & Key
Rodent Screen	None
RoHS Status	ROHS COMPLIANT
Service Factor	1.15
Shaft Diameter	0.875 IN
Shaft Extension Location	Pulley End
Shaft Ground Indicator	No Shaft Grounding
Shaft Rotation	Reversible
Shaft Slinger Indicator	No Slinger
Speed	3470 rpm
Speed Code	Single Speed
Starting Method	Direct on line
Thermal Device - Bearing	None
Thermal Device - Winding	None

Vibration Sensor Indicator	No Vibration Sensor
Winding Thermal 1	None
Winding Thermal 2	None

Nameplate

NP4427AAA01

CAT #	JMFSWDM3559T-E	WT	85	LBS	
SPEC	35E4781R930G1	ENCL	TEFC		
SER #		CC	010A	IP	69
HP	3	MAG CUR	2.6/1.3		
VOLTS	230/460	NEMA NOM. EFF		86.5	
AMPS	7.4/3.7	PF	91		
RATING	40C AMB-CONT				
RPM	3470	MAX RPM	5400		
FRAME	145JM	HZ	60	CODE	P
		CLASS	H		
SER.F.	1.15	SF AMP		PH	3
		DES	A		
DE	6206	ODE	6205		
LUBRICATION	POLYREX EM				
ID LOGO	INVERTER TYPE	VPWM	60	TO	90
					1.5:1
ID LOGO	WK2	0.127	CT	15	TO
					60
ID LOGO	SL HZ	2.2	VT	3	TO
					60
					20:1
YR		QR			

Parts List

Part number	Description	Quantity
SA350770	SA 35E4781R930G1	1.000 ea
RA339434	RA 35E4781R930G1	1.000 ea
34FN3002A01SP	EXTERNAL FAN, PLASTIC, .637/.639 HUB W/	1.000 ea
35CB1017A02	5/36 MID SECT - 3 PC. CONDUIT BOX 3/4 N	1.000 ea
HA3424S48	STUD - M6X1.0 THDS X 3.00"	1.000 ea
11XW1032G08	10-32 X .50, TAPTITE II, HEX WSHR SLTD U	1.000 ea
HW3001B02	BRASS CUP WASHER W/GROUND SYMBOL TAB,	1.000 ea
35EP1940A05	FRONT TEFC 205 BRG (STAINLESS)	1.000 ea
RM1070A25	O-RING, VITON/FKM .070CS X 6.190ID	1.000 ea
HW4600G01	.984X1.499X.25 VITON SLICK SERIES LIP	1.000 ea
HW4600E99	25 X 42 X 6 AFX SEAL, GRAPHITE INFUSED V	1.000 ea
HW4500S33	1/8 NPT STAINLESS #304 SS PLUG	4.000 ea
HW5100A05	WVY WSHR F/205 & 304 BRGS	1.000 ea
35EP1936A02	PU EP ENCL 206 BRG 56C/143-5TC (STAINLES	1.000 ea
RM1070A25	O-RING, VITON/FKM .070CS X 6.190ID	1.000 ea
HW4600G02	30 X 47 X 8 LIP SEAL, GRAPHITE INFUSED V	1.000 ea
HW4600F25	30 X 48 X 4.5 AFX SEAL, GRAPHITE INFUSED	1.000 ea
HW4500S33	1/8 NPT STAINLESS #304 SS PLUG	4.000 ea
RM1070A26	O-RING,4.5MM I.D.X1.5MM C.S. (VITON)	4.000 ea
35FH4005A39	IEC FH NO GREASER DEBURR/CLEAN - SS	1.000 ea
10XN1032FS06	HEX HD CAP SCREW 10-32 X 3/8 SS FOOD SAF	3.000 ea
RM1070A81	O-RING, -043 VITON/FKM .070CS X 3.489ID	1.000 ea
35CB1513A01	35-36-37 MACH. LID - 3 PC. CONDUIT BOX	1.000 ea
RM1070A81	O-RING, -043 VITON/FKM .070CS X 3.489ID	1.000 ea
HW2502D13	SS KEY, 3/16 SQ X 1.375	1.000 ea
HA7000A01	KEY RETAINER 7/8" DIA SHAFT	1.000 ea
MJ5001A27	32220KN GRAY SEALER *MIN BUY 4 QTS=1GAL	0.005 qt
MJ5004A93	FOOD GRADE (H1 RATED) ANTISEIZE THRD COM	0.005 ea
HA1025A21	WSHR,FELT .125" THK	1.000 ea
HA5027A09	DRAIN KIT,(2)HA4002A03 BAGGED W/LABEL	1.000 ea
MJ1000A02	GREASE, POLYREX EM EXXON	0.050 lb

19XB0818S12	8-18X3/4 HXWS TYB HIGH-LOW	1.000 ea
WD5603A01	KIT, CLOSED-END LEAD SPLICE (18-14GA)	1.000 ea
HA3100FS61	THRUBOLT, 10-32 X 11.750 SS FOOD SAFE	4.000 ea
GOPA1000	PKG GRP, PRINT PK1026A06	1.000 ea
MN416A01	TAG-INSTAL-MAINT no wire (2500 bx)11/25	1.000 ea
FE-0000016	ZTRG FE ASSEMBLY	1.000 ea
PE-0000010	ZRTG PE ASSEMBLY	1.000 ea

ABB Motors and Mechanical Inc.

WINDING # 35WGR930

3 HP 3 PH 60 HZ 3470 RPM 460 V 3546M

Typical performance - not guaranteed values.

TORQUES (LB-FT): PO=17.2 PU=10.5 LR=17 LRA=48.3

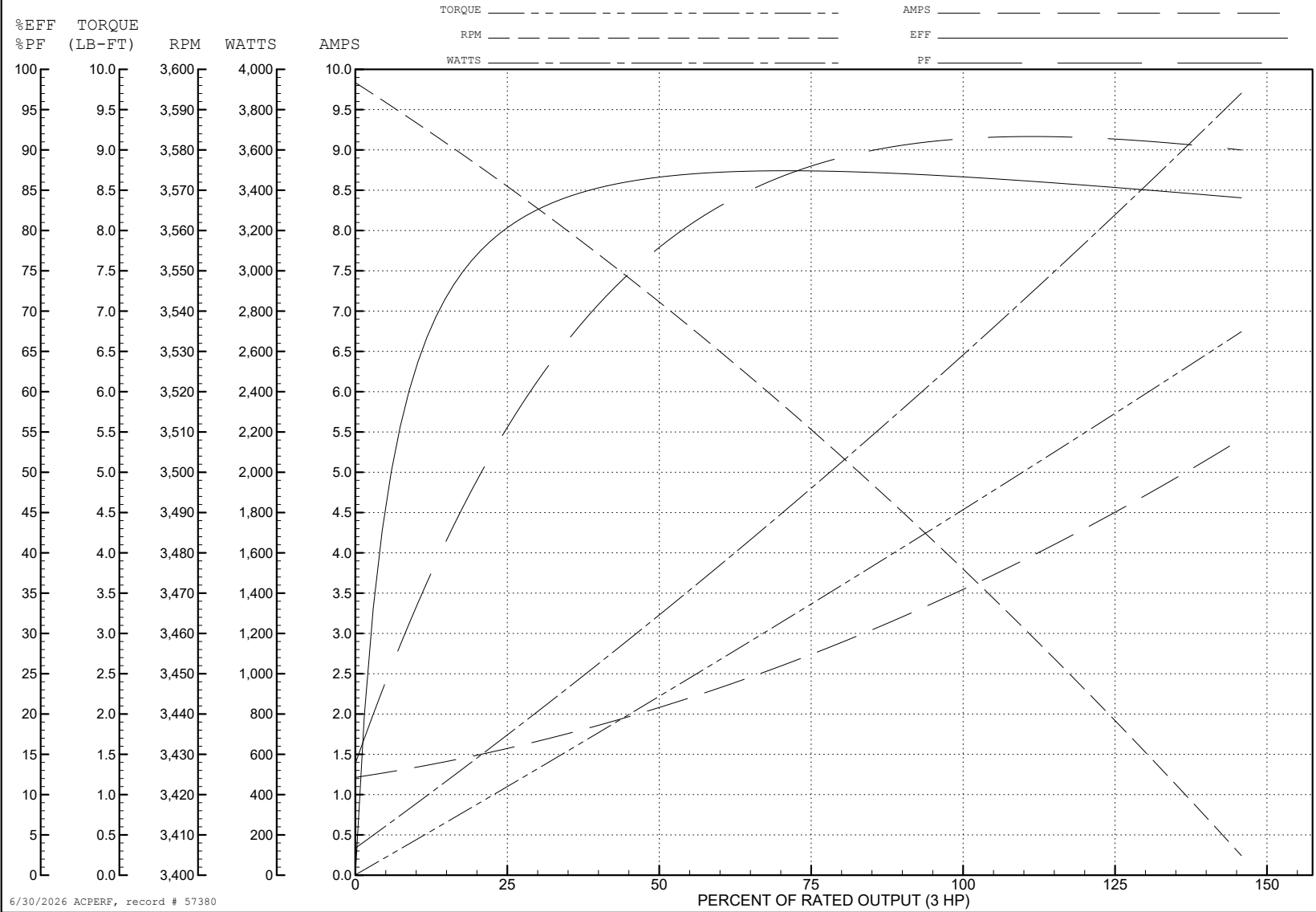

6/30/2026 ACPERF, record # 57380

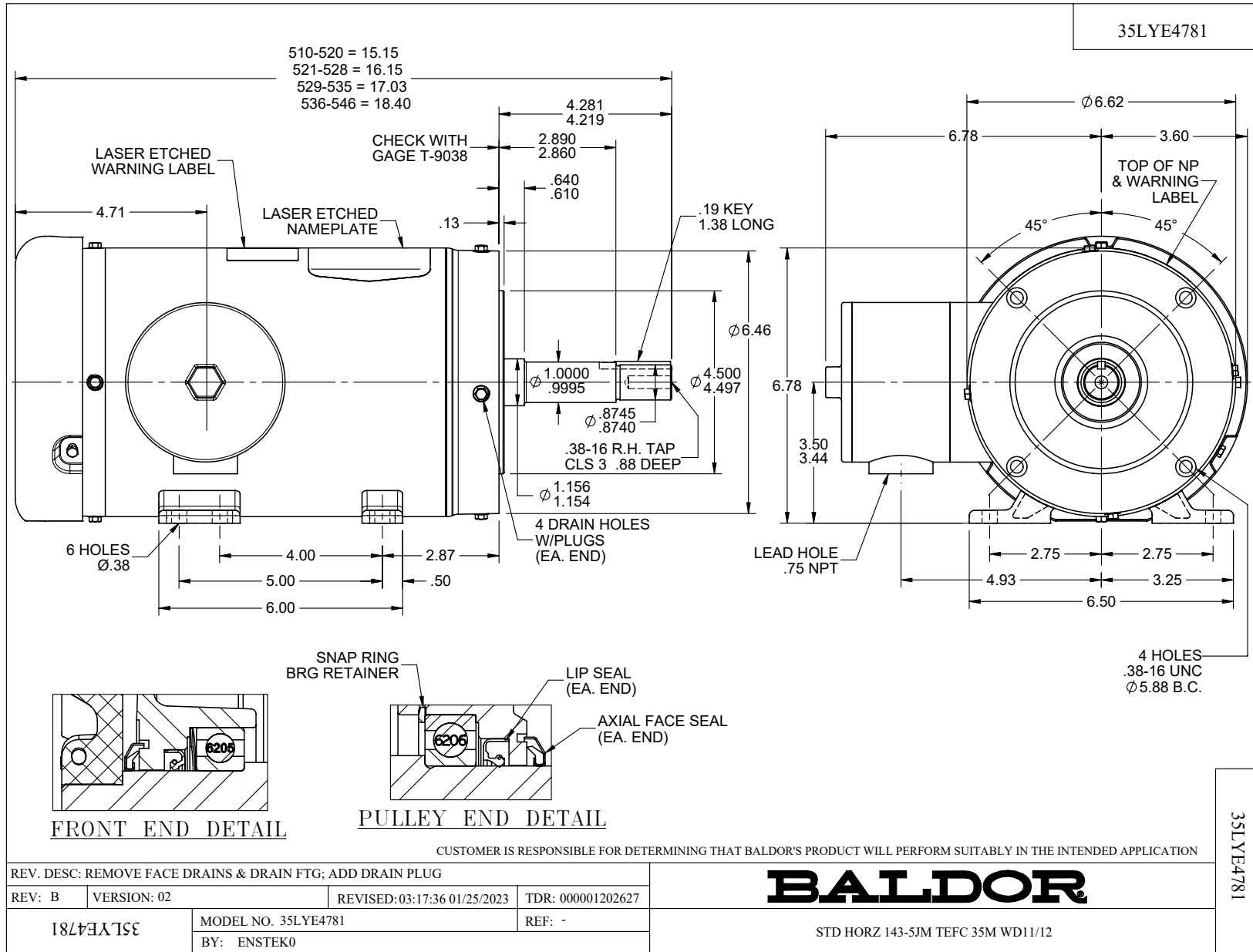

CD0005



LOW VOLTAGE
(2Y)



LINE

HIGH VOLTAGE
(1Y)



LINE

NOTES:

1. INTERCHANGE ANY TWO LINE LEADS TO REVERSE ROTATION.
2. OPTIONAL THERMOSTATS ARE PROVIDED WHEN SPECIFIED.
3. ACTUAL NUMBER OF INTERNAL PARALLEL CIRCUITS MAY BE A MULTIPLE OF THOSE SHOWN ABOVE.
4. LEAD COLORS ARE OPTIONAL. LEADS MUST ALWAYS BE NUMBERED AS SHOWN.

CD0005

REV. DESC: REVISE TO SHOW OPTIONAL COLORS

REV. LTR: E BY: JLP REVISED: 01/19/99 10:15 TDR: 0171435

500000

FILE: AAA00005140

MDL: -

MTL: -

BALDOR ELECTRIC Co.

3PH, DV, 9 LEADS