



Customer information packet

VFSWDM3558-E

2HP, 1765RPM, 3PH, 60HZ, 56C, 3528M, TEFC, F1, N

Class - None

Division - Not Applicable

Specifications

Enclosure	TEFC
Frame	56C
Frame Material	Stainless Steel
Frequency	60.00 Hz
Motor Letter Type	Three Phase
Output @ Frequency	2.000 HP @ 60 HZ
Phase	3
Synchronous Speed @ Frequency	1800 RPM @ 60 HZ
Voltage @ Frequency	230.0 V @ 60 HZ
	460.0 V @ 60 HZ
XP Class and Group	None
XP Division	Not Applicable
Agency Approvals	CSA EEV
	NEMA PREMIUM
	NEMA_PREMIUM
	UR
Ambient Temperature	40 °C
Auxillary Box	No Auxillary Box
Auxillary Box Lead Termination	None
Base Indicator	No Mounting
Bearing Grease Type	Polyrex EM (-20F +300F)
Blower	None
Current @ Voltage	5.600 A @ 208.0 V
	5.300 A @ 230.0 V
	2.650 A @ 460.0 V
Design Code	B
Drip Cover	No Drip Cover
Duty Rating	CONT
Efficiency @ 100% Load	86.5 %
Electrically Isolated Bearing	Not Electrically Isolated
Feedback Device	NO FEEDBACK
Front Shaft Indicator	None

Part detail

Revision	J
Type	AC
Mech. spec.	35E4649
Base	
Status	PRD/A
Elec. spec.	35WGZ821
Layout	35LYE4649
Eff. date	09-07-2023
CD Diagram	CD0005
Poles	04
Leads	9#18 Y
Proprietary	False
Created date	11-23-2021

Heater Indicator	No Heater
High Voltage Full Load Amps	2.7 a
Insulation Class	H
Inverter Code	Inverter Duty
KVA Code	K
Lifting Lugs	No Lifting Lugs
Locked Bearing Indicator	Locked Bearing
Motor Finish	UNPAINTED
Motor Lead Quantity/Wire Size	9 @ 18 AWG
Motor Lead Termination	Flying Leads
Motor Standards	NEMA
Motor Type	3528M
Mounting Arrangement	F1
Number of Poles	4
Overall Length	13.96 IN
Power Factor	81
Product Family	WD All SD Non-Encapsulated
Pulley End Bearing Type	Sealed Bearing
Pulley Face Code	C-Face
Pulley Shaft Indicator	Standard
Rodent Screen	None
Service Factor	1.15
Shaft Diameter	0.625 IN
Shaft Ground Indicator	No Shaft Grounding
Shaft Rotation	Reversible
Shaft Slinger Indicator	No Slinger
Speed	1765 rpm
Speed Code	Single Speed
Starting Method	Direct on line
Thermal Device - Bearing	None
Thermal Device - Winding	None
Vibration Sensor Indicator	No Vibration Sensor
Winding Thermal 1	None
Winding Thermal 2	None

Nameplate

NP4427AAA01										
CAT #	VFSWDM3558-E				WT	45	LBS			
SPEC	35E4649Z821G1				ENCL	TEFC				
SER #					CC	010A	IP	69		
HP	2		MAG CUR	2.8/1.4						
VOLTS	230/460				NEMA NOM. EFF	86.5				
AMPS	5.3/2.65				PF	81				
RATING	40C AMB-CONT									
RPM	1765				MAX RPM	2700				
FRAME	56C	HZ	60	CODE	K	CLASS	H			
SER.F.	1.15	SF AMP	6/3		PH	3	DES	B		
DE	6205		ODE	6205						
LUBRICATION	POLYREX EM									
ID LOGO	INVERTER TYPE	VPWM	CHP	60	TO	90	1.5:1			
ID LOGO	WK2	0.202	CT	15	TO	60	4:1			
ID LOGO	SL HZ	1.2	VT	3	TO	60	20:1			
					QR					
YR										

Parts list

Part number	Description	Quantity
SA399309	SA 35E4649Z821G1	1.000 ea
RA390368	RA 35E4649Z821G1	1.000 ea
34FN3002B01	EXTERNAL FAN, PLASTIC, .637/.639 HUB W/	1.000 ea
35CB1017A01	35/36 MID SECT - 3 PC. CONDUIT BOX 1/2 N	1.000 ea
HA3424S48	STUD - M6X1.0 THDS X 3.00"	1.000 ea
RM1070A81	O-RING, -043 VITON/FKM .070CS X 3.489ID	1.000 ea
35CB1513A01	35-36-37 MACH. LID - 3 PC. CONDUIT BOX	1.000 ea
11XW1032G08	10-32 X .50, TAPTITE II, HEX WSHR SLTD U	1.000 ea
HW3001B02	BRASS CUP WASHER W/GROUND SYMBOL TAB,	1.000 ea
35EP1940A05	FRONT TEFC 205 BRG (STAINLESS)	1.000 ea
RM1070A25	O-RING, VITON/FKM .070CS X 6.190ID	1.000 ea
HW4600G01	.984X1.499X.25 VITON SLICK SERIES LIP	1.000 ea
HW4600E99	25 X 42 X 6 AFX SEAL, GRAPHITE INFUSED V	1.000 ea
HW4500S33	1/8 NPT STAINLESS #304 SS PLUG	4.000 ea
HW4500S33	1/8 NPT STAINLESS #304 SS PLUG	4.000 ea
HW5100A05	WVY WSHR F/205 & 304 BRGS	1.000 ea
35EP1935A02	PULLEY 56C/143-5TC ENCL 205 BRG	1.000 ea
RM1070A25	O-RING, VITON/FKM .070CS X 6.190ID	1.000 ea
HW4600G01	.984X1.499X.25 VITON SLICK SERIES LIP	1.000 ea
HW4600E99	25 X 42 X 6 AFX SEAL, GRAPHITE INFUSED V	1.000 ea
RM1070A26	O-RING,4.5MM I.D.X1.5MM C.S. (VITON)	4.000 ea
35FH4005A39	IEC FH NO GREASER DEBURR/CLEAN - SS	1.000 ea
10XN1032FS06	HEX HD CAP SCREW 10-32 X 3/8 SS FOOD SAF	3.000 ea
RM1070A81	O-RING, -043 VITON/FKM .070CS X 3.489ID	1.000 ea
HW2502D13	SS KEY, 3/16 SQ X 1.375	1.000 ea
HA7000A04	KEY RETAINER 0.625 DIA SHAFTS	1.000 ea
MJ5001A27	32220KN GRAY SEALER *MIN BUY 4 QTS=1GAL	0.005 qt
MJ5004A93	FOOD GRADE (H1 RATED) ANTISEIZE THRD COM	0.005 ea
HA1025A21	WSHR,FELT .125" THK	1.000 ea
HA5027A09	DRAIN KIT,(2)HA4002A03 BAGGED W/LABEL	1.000 ea
MJ1000A02	GREASE, POLYREX EM EXXON	0.050 lb

19XB0818S12	8-18X3/4 HXWS TYB HIGH-LOW	1.000 ea
WD5603A01	KIT, CLOSED-END LEAD SPLICE (18-14GA)	1.000 ea
HA3100FS25	THRUBOLT, 10-32 X 9.500 SS FOOD SAFE	4.000 ea
36PA1000	PKG GRP, PRINT PK1016A06	1.000 ea
PK3082	STYROFOAM CRADLE	1.000 ea
MN416A01	TAG-INSTAL-MAINT no wire (2100bx)4/22	1.000 ea
FE-0000016	ZTRG FE ASSEMBLY	1.000 ea
PE-0000016	ZRTG PE ASSEMBLY	1.000 ea

AC Induction Motor Performance Data

Record # 87359

Preliminary Data Sheet

Winding: 35WGZ821-R001		Type: 3528M		Enclosure: TEFC	
Nameplate Data			460 V, 60 Hz: High Voltage Connection		
Rated Output (HP)	2		Full Load Torque	5.97 LB-FT	
Volts	230/460		Start Configuration	direct on line	
Full Load Amps	5.6/2.8		Breakdown Torque	21 LB-FT	
R.P.M.	1760		Pull-up Torque	11.9 LB-FT	
Hz	60	Phase	3	Locked-rotor Torque	15.1 LB-FT
NEMA Design Code	B		KVA Code	K	
Service Factor (S.F.)	1.15		Starting Current	22.5 A	
NEMA Nom. Eff.	86.5	Power Factor	81	No-load Current	1.55 A
Rating - Duty	40C AMB-CONT		Line-line Res. @ 25°C	9.54 Ω	
S.F. Amps	6.3/3.15		Temp. Rise @ Rated Load	64°C	
			Temp. Rise @ S.F. Load	77°C	
			Locked-rotor Power Factor	57.9	
			Rotor inertia	0.202 LB-FT ²	

Load Characteristics 460 V, 60 Hz, 2 HP

% of Rated Load	25	50	75	100	125	150	S.F.
Power Factor	36	57	70	78	82	85	83
Efficiency	79.5	86.2	87.4	87	85.7	83.9	86.3
Speed	1791	1782	1772	1762	1750	1738	1758
Line amperes	1.64	1.91	2.3	2.78	3.33	3.94	3.02

ABB Motors and Mechanical Inc.

WINDING # 35WGZ821

Typical performance - not guaranteed values.

2 HP 3 PH 60 HZ 1760 RPM 460 V 3528M

TORQUES (LB-FT): PO=21 PU=11.9 LR=15.1 LRA=22.5

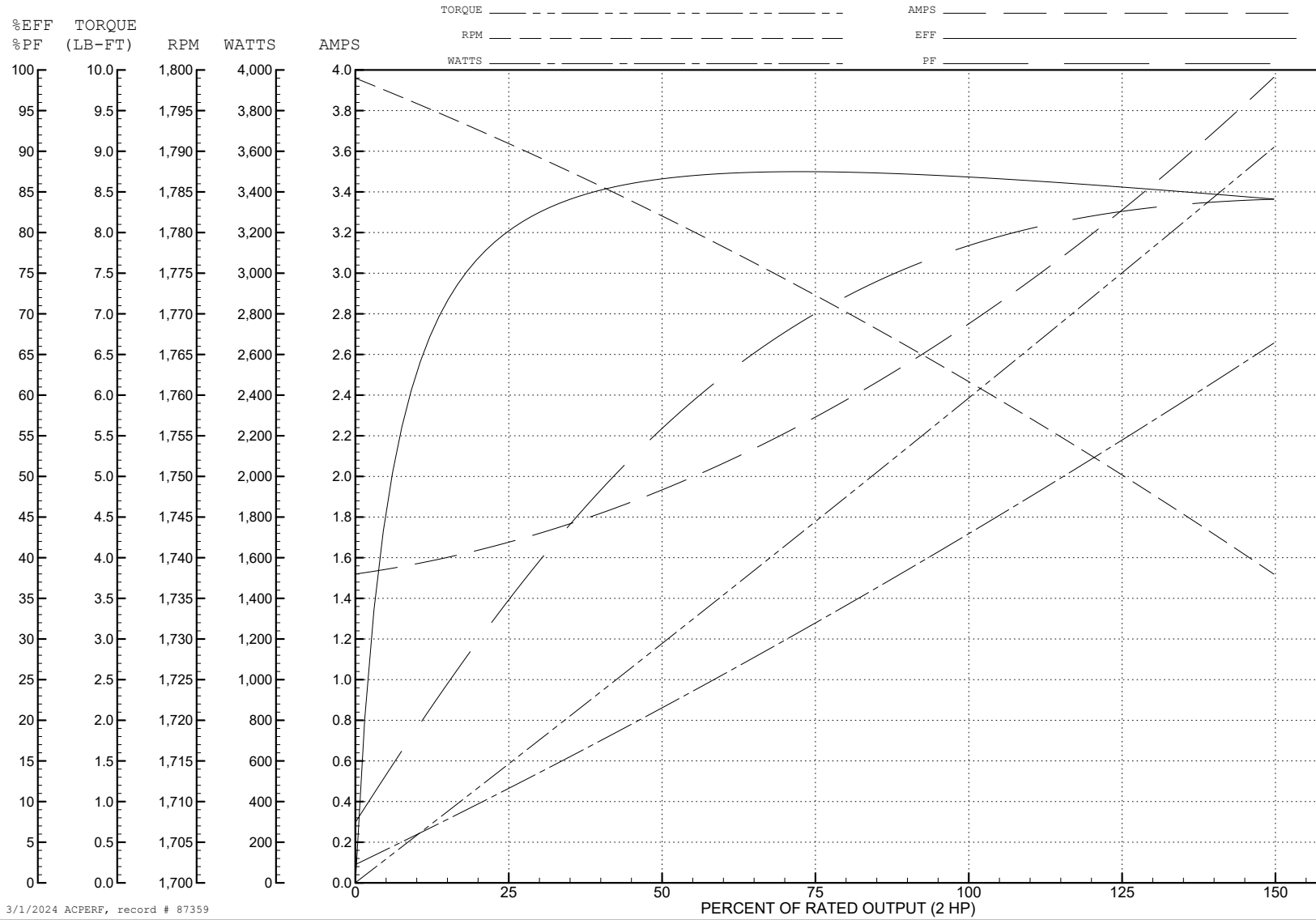

3/1/2024 ACPERF, record # 87359

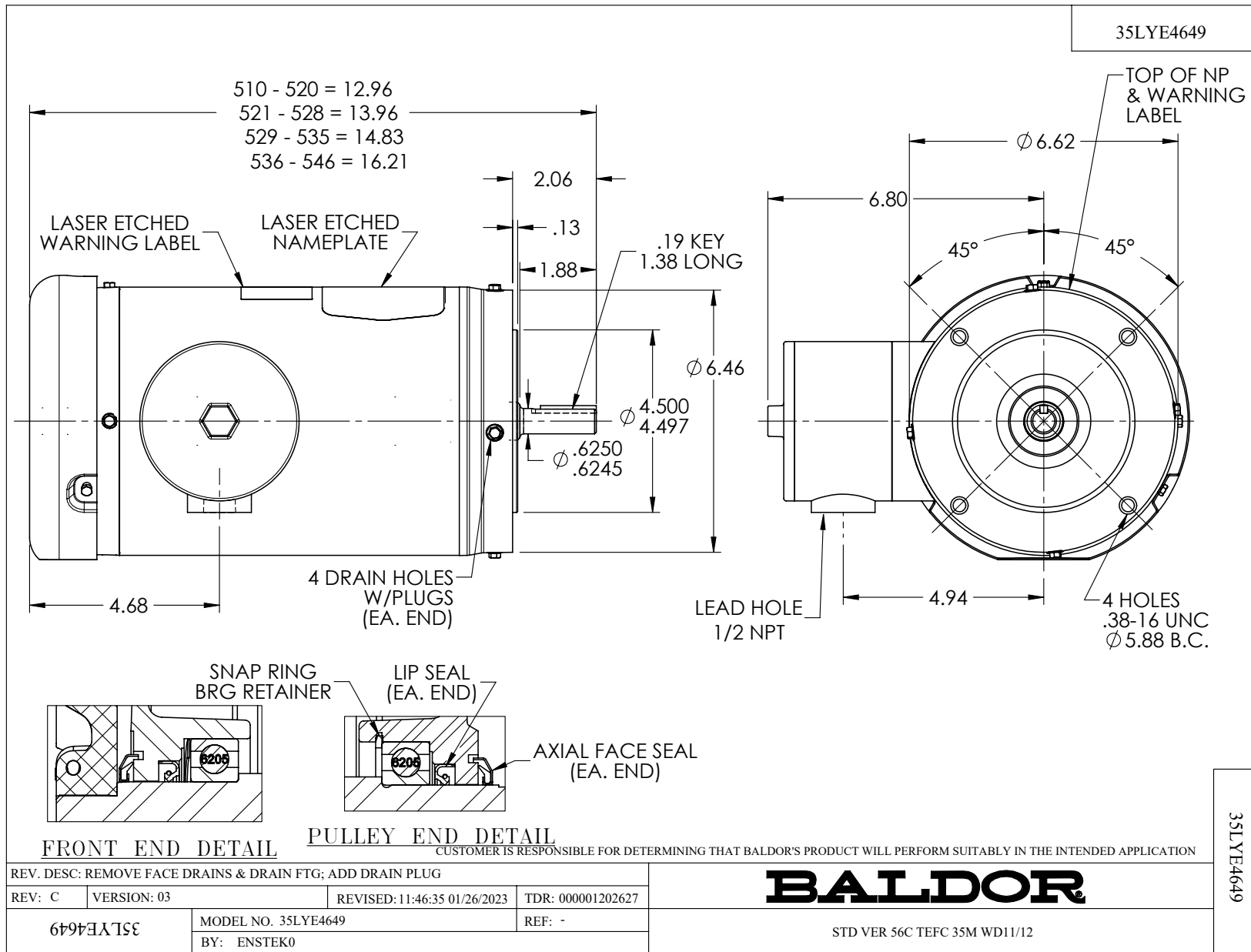

CD0005



LOW VOLTAGE
(2Y)



LINE

HIGH VOLTAGE
(1Y)

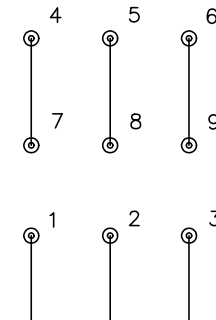

LINE

NOTES:

1. INTERCHANGE ANY TWO LINE LEADS TO REVERSE ROTATION.
2. OPTIONAL THERMOSTATS ARE PROVIDED WHEN SPECIFIED.
3. ACTUAL NUMBER OF INTERNAL PARALLEL CIRCUITS MAY BE A MULTIPLE OF THOSE SHOWN ABOVE.
4. LEAD COLORS ARE OPTIONAL. LEADS MUST ALWAYS BE NUMBERED AS SHOWN.

CD0005

REV. DESC: REVISE TO SHOW OPTIONAL COLORS			
REV. LTR: E	BY: JLP	REVISED: 01/19/99 10:15	TDR: 0171435
S00000		FILE: AAA00005140	MDL: -
		MTL: -	

BALDOR ELECTRIC Co.

3PH, DV, 9 LEADS