

ABB BALDOR RELIANCE III

Customer information packet

VFSWDNM3555-E

2HP, 3480RPM, 3PH, 60HZ, 56C, 3546M, TENV, F1, N

Class - None

Division - Not Applicable

Specifications

Enclosure	TENV
Frame	56C
Frame Material	Stainless Steel
Frequency	60.00 Hz
Haz Area Class and Group	None
Haz Area Division	Not Applicable
Motor Letter Type	Three Phase
Output @ Frequency	2.000 HP @ 60 HZ
Phase	3
Synchronous Speed @ Frequency	3600 RPM @ 60 HZ
Voltage @ Frequency	230.0 V @ 60 HZ 460.0 V @ 60 HZ
Agency Approvals	UR CSA
Ambient Temperature	40 °C
Auxiliary Box	NO AUXILLARY BOX
Auxiliary Box Lead Termination	None
Base Indicator	No Mounting
Bearing Grease Type	Polyrex EM (-20F +300F)
Blower	None
Current @ Voltage	2.400 A @ 460.0 V 4.800 A @ 230.0 V
Design Code	B
Drip Cover	No Drip Cover
Duty Rating	CONT
Efficiency @ 100% Load	88.5 %
Electrically Isolated Bearing	Not Electrically Isolated
Feedback Device	NO FEEDBACK
Front Face Code	Standard
Front Shaft Indicator	None
Heater Indicator	No Heater
High Voltage Full Load Amps	2.4 a

Part Detail

Revision	N
Type	AC
Mech. spec.	35E4656
Base	
Status	PRD/A
Elec. spec.	35WGL288
Layout	35LYE4656
Eff. date	08-14-2023
CD Diagram	CD0005
Poles	02
Leads	9#18,0#,0#,0# Y
Proprietary	False
Created date	07-10-2017

Insulation Class	H
Inverter Code	Not Inverter
KVA Code	N
Lifting Lugs	No Lifting Lugs
Locked Bearing Indicator	Locked Bearing
Motor Finish	UNPAINTED
Motor Lead Exit	Ko Box
Motor Lead Quantity/Wire Size	@ 0 AWG 9 @ 18 AWG
Motor Lead Termination	Flying Leads
Motor Standards	NEMA
Motor Type	3546M
Mounting Arrangement	F1
Number of Poles	2
Overall Length	15.04 IN
Power Factor	89
Product Family	WD All SS Encapsulated
Pulley End Bearing Type	Sealed Bearing
Pulley Face Code	C-Face
Pulley Shaft Indicator	Standard
Rodent Screen	None
RoHS Status	ROHS COMPLIANT
Service Factor	1.15
Shaft Diameter	0.625 IN
Shaft Extension Location	Pulley End
Shaft Ground Indicator	No Shaft Grounding
Shaft Rotation	Reversible
Shaft Slinger Indicator	No Slinger
Speed	3480 rpm
Speed Code	Single Speed
Starting Method	Direct on line
Thermal Device - Bearing	None
Thermal Device - Winding	None
Vibration Sensor Indicator	No Vibration Sensor

Winding Thermal 1

None

Winding Thermal 2

None

Nameplate

NP4427AAA01											
CAT #	VFSWDNM3555-E				WT	63	LBS				
SPEC	35E4656L288G1				ENCL	TENV					
SER #					CC	010A	IP	69			
HP	2	MAG CUR		1.7/.85							
VOLTS	230/460		NEMA NOM. EFF		88.5						
AMPS	4.8/2.4		PF		89						
RATING	40C AMB-CONT										
RPM	3480		MAX RPM		5400						
FRAME	56C	HZ	60	CODE	N	CLASS	H				
SER.F.	1.15	SF AMP			PH	3	DES	B			
DE	6205	ODE	6205								
LUBRICATION	POLYREX EM										
ID LOGO	INVERTER TYPE		VPWM	CHP	60	TO	90	1.5:1			
ID LOGO	WK2	0.127	CT	15	TO	60	4:1				
ID LOGO	SL HZ	2	VT	3	TO	60	20:1				
YR					QR						

Parts List

Part number	Description	Quantity
SA343178	SA 35E4656L288G1	1.000 ea
RA331624	RA 35E4656L288G1	1.000 ea
35CB1017A01	35/36 MID SECT - 3 PC. CONDUIT BOX 1/2 N	1.000 ea
HA3424S48	STUD - M6X1.0 THDS X 3.00"	1.000 ea
RM1070A81	O-RING, -043 VITON/FKM .070CS X 3.489ID	1.000 ea
35CB1513A01	35-36-37 MACH. LID - 3 PC. CONDUIT BOX	1.000 ea
11XW1032G08	10-32 X .50, TAPTITE II, HEX WSHR SLTD U	1.000 ea
HW3001B02	BRASS CUP WASHER W/GROUND SYMBOL TAB,	1.000 ea
35EP1940A03	FRONT TENV 205 BRG (STAINLESS)	1.000 ea
RM1070A25	O-RING, VITON/FKM .070CS X 6.190ID	1.000 ea
HW4500S33	1/8 NPT STAINLESS #304 SS PLUG	4.000 ea
HW5100A05	WVY WSHR F/205 & 304 BRGS	1.000 ea
35EP1935A02	PULLEY 56C/143-5TC ENCL 205 BRG	1.000 ea
RM1070A25	O-RING, VITON/FKM .070CS X 6.190ID	1.000 ea
HW4600G01	.984X1.499X.25 VITON SLICK SERIES LIP	1.000 ea
HW4600E99	25 X 42 X 6 AFX SEAL, GRAPHITE INFUSED V	1.000 ea
HW4500S33	1/8 NPT STAINLESS #304 SS PLUG	4.000 ea
RM1070A26	O-RING,4.5MM I.D.X1.5MM C.S. (VITON)	4.000 ea
RM1070A81	O-RING, -043 VITON/FKM .070CS X 3.489ID	1.000 ea
HW2502D13	SS KEY, 3/16 SQ X 1.375	1.000 ea
HA7000A04	KEY RETAINER 0.625 DIA SHAFTS	1.000 ea
MJ5001A27	32220KN GRAY SEALER *MIN BUY 4 QTS=1GAL	0.005 qt
MJ5004A93	FOOD GRADE (H1 RATED) ANTISEIZE THRD COM	0.005 ea
HA1025A21	WSHR,FELT .125" THK	1.000 ea
HA5027A09	DRAIN KIT,(2)HA4002A03 BAGGED W/LABEL	1.000 ea
MJ1000A02	GREASE, POLYREX EM EXXON	0.050 lb
WD5603A01	KIT, CLOSED-END LEAD SPLICE (18-14GA)	1.000 ea
HA3100FS61	THRUBOLT, 10-32 X 11.750 SS FOOD SAFE	4.000 ea
36PA1000	PKG GRP, PRINT PK1016A08	1.000 ea
PK3082	STYROFOAM CRADLE	1.000 ea
MN416A01	TAG-INSTAL-MAINT no wire (2500 bx)11/25	1.000 ea

PE-0000010	ZRTG PE ASSEMBLY	1.000 ea
FE-0000007	ZRTG FE ASSEMBLY	1.000 ea

ABB Motors and Mechanical Inc.

WINDING # 35WGL288

Typical performance - not guaranteed values.

2 HP 3 PH 60 HZ 3480 RPM 460 V 3546M

TORQUES (LB-FT): PO=17.3 PU=6.76 LR=14.8 LRA=29.7

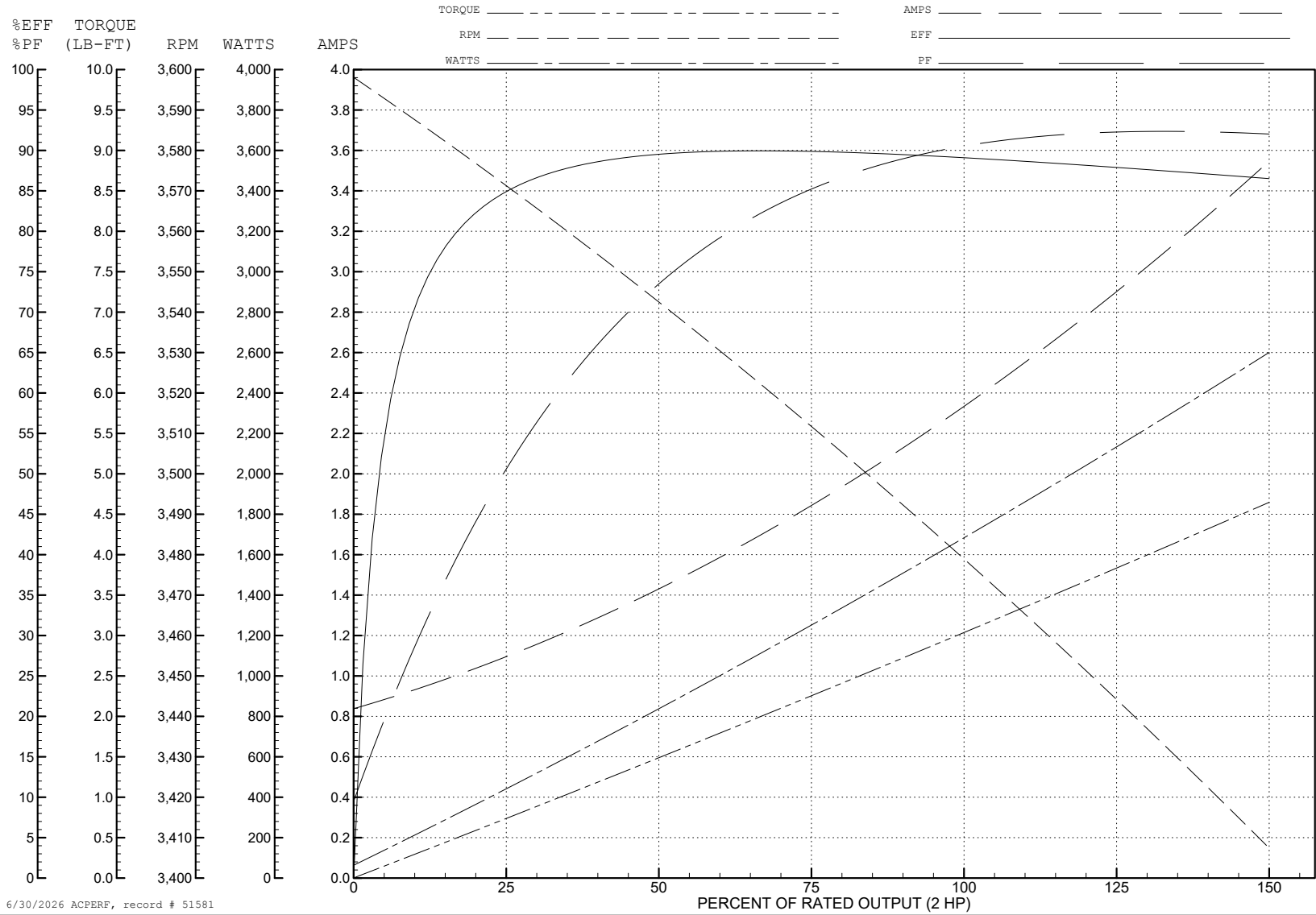

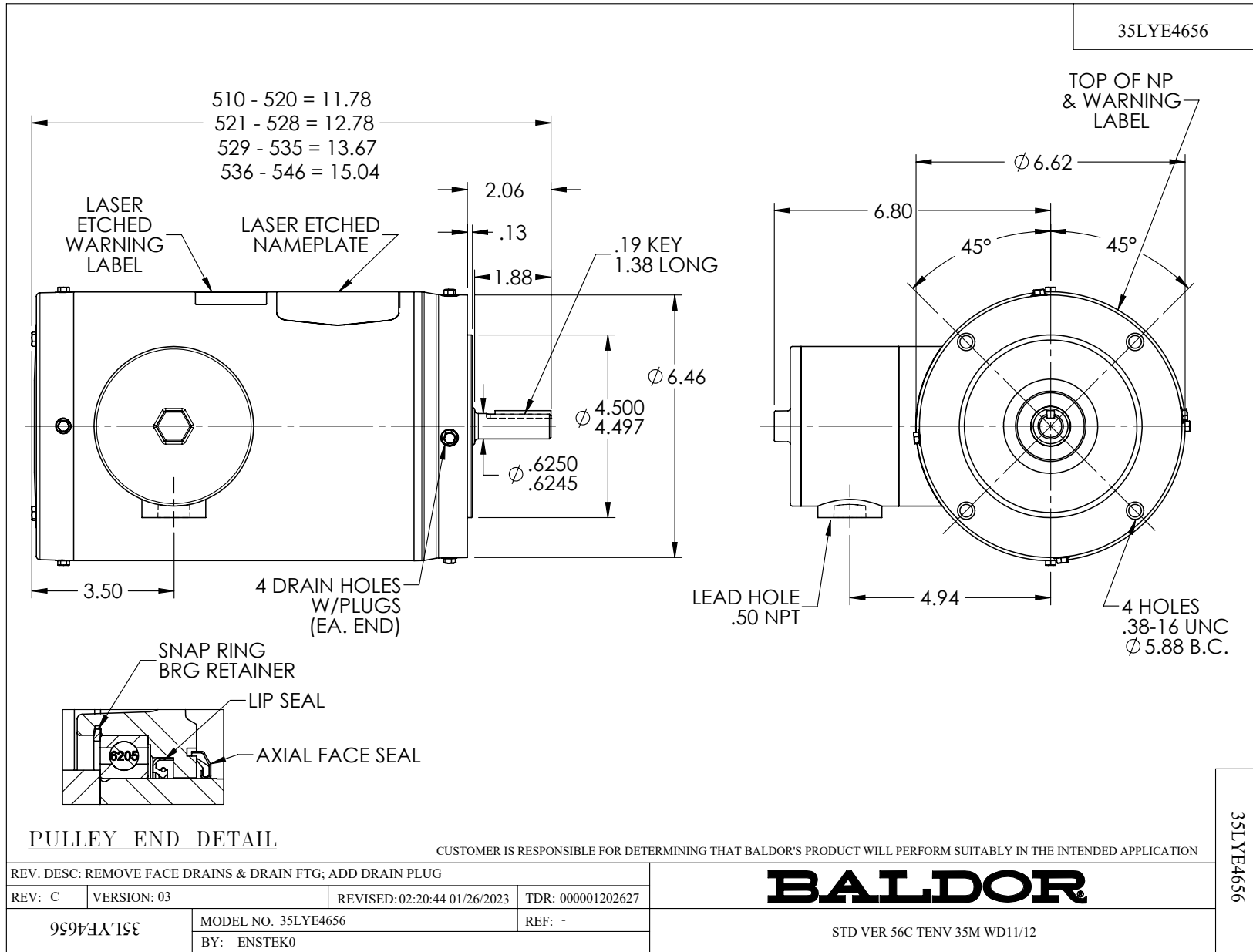

CD0005



LOW VOLTAGE
(2Y)

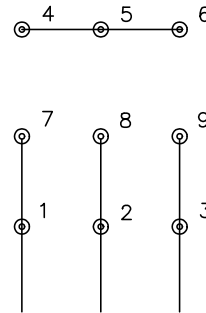

LINE

HIGH VOLTAGE
(1Y)



LINE

NOTES:

1. INTERCHANGE ANY TWO LINE LEADS TO REVERSE ROTATION.
2. OPTIONAL THERMOSTATS ARE PROVIDED WHEN SPECIFIED.
3. ACTUAL NUMBER OF INTERNAL PARALLEL CIRCUITS MAY BE A MULTIPLE OF THOSE SHOWN ABOVE.
4. LEAD COLORS ARE OPTIONAL. LEADS MUST ALWAYS BE NUMBERED AS SHOWN.

CD0005

REV. DESC: REVISE TO SHOW OPTIONAL COLORS

REV. LTR: E BY: JLP REVISED: 01/19/99 10:15 TDR: 0171435

500000

FILE: AAA00005140

MDL: -

MTL: -

BALDOR ELECTRIC Co.

3PH, DV, 9 LEADS