

BALDOR® • RELIANCE 

Product Information Packet

EM4104T-5G

30HP,1770RPM,3PH,60HZ,286T,1056M,TEFC,F1

Part Detail							
Revision:	W	Status:	PRD/A	Change #:		Proprietary:	No
Type:	AC	Elec. Spec:	10WGY759	CD Diagram:	CD0006	Mfg Plant:	
Mech. Spec:	10H279	Layout:	10LYH279	Poles:	04	Created Date:	02-11-2011
Base:	RG	Eff. Date:	09-11-2019	Leads:	3#10		

Specs			
Catalog Number:	EM4104T-5G	Inverter Code:	Inverter Ready
Enclosure:	TEFC	KVA Code:	G
Frame:	286T	Lifting Lugs:	Standard Lifting Lugs
Frame Material:	Iron	Locked Bearing Indicator:	Locked Bearing
Output @ Frequency:	30.000 HP @ 60 HZ	Motor Lead Quantity/Wire Size:	3 @ 10 AWG
Synchronous Speed @ Frequency:	1800 RPM @ 60 HZ	Motor Lead Exit:	Ko Box
Voltage @ Frequency:	575.0 V @ 60 HZ	Motor Lead Termination:	Flying Leads
XP Class and Group:	None	Motor Type:	1056M
XP Division:	Not Applicable	Mounting Arrangement:	F1
Agency Approvals:	CSA	Power Factor:	83
	CSA EEV	Product Family:	General Purpose
	UR	Pulley End Bearing Type:	Ball
Auxillary Box:	No Auxillary Box	Pulley Face Code:	Standard
Auxillary Box Lead Termination:	None	Pulley Shaft Indicator:	Standard
Base Indicator:	Rigid	Rodent Screen:	None
Bearing Grease Type:	Polyrex EM (-20F +300F)	Shaft Extension Location:	Pulley End
Blower:	None	Shaft Ground Indicator:	Shaft Grounding
Current @ Voltage:	29.000 A @ 575.0 V	Shaft Rotation:	Reversible

Design Code:	A	Shaft Slinger Indicator:	Shaft Slinger
Drip Cover:	No Drip Cover	Speed Code:	Single Speed
Duty Rating:	CONT	Motor Standards:	NEMA
Electrically Isolated Bearing:	Not Electrically Isolated	Starting Method:	Direct on line
Feedback Device:	NO FEEDBACK	Thermal Device - Bearing:	None
Front Face Code:	Standard	Thermal Device - Winding:	None
Front Shaft Indicator:	None	Vibration Sensor Indicator:	No Vibration Sensor
Heater Indicator:	No Heater	Winding Thermal 1:	None
Insulation Class:	H	Winding Thermal 2:	None

Nameplate NP3443L										
CAT.NO.	EM4104T-5G				CUST. P/N				ENCL	TEFC
SPEC.	10H279Y759G1		CC	010A	FRAME	286T		SER.NO.		
HP	30		CLASS	H	HZ	60				
R.P.M.	1770		PH	3	DES	A				
VOLTS	575		CODE	G	ODE BRG	6309		DE BRG	6311	
AMPS	29		USABLE AT 208V							
RATING	40C AMB-CONT		NEMA NOM. EFF.	93.6		GREASE	POLYREX EM			
P.F.	83		SER.F.	1.15		VPWM INVERTER READY				
HTR-VOLTS			HTR-AMPS			HTR-WATTS				

AC Induction Motor Performance Data

Record # 50235 - Typical performance - not guaranteed values

Winding: 10WGY759-R004	Type: 1056M	Enclosure: TEFC
-------------------------------	--------------------	------------------------

Nameplate Data				575 V, 60 Hz: Single Voltage Motor	
Rated Output (HP)	30			Full Load Torque	89.2 LB-FT
Volts	575			Start Configuration	direct on line
Full Load Amps	29			Breakdown Torque	255 LB-FT
R.P.M.	1770			Pull-up Torque	120 LB-FT
Hz	60	Phase	3	Locked-rotor Torque	136 LB-FT
NEMA Design Code	B	KVA Code	G	Starting Current	177 A
Service Factor (S.F.)	1.15			No-load Current	11.5 A
NEMA Nom. Eff.	93.6	Power Factor	83	Line-line Res. @ 25°C	0.375 Ω
Rating - Duty	40C AMB-CONT			Temp. Rise @ Rated Load	58°C
S.F. Amps				Temp. Rise @ S.F. Load	71°C
				Locked-rotor Power Factor	32
				Rotor inertia	4.45 LB-FT ²

Load Characteristics 575 V, 60 Hz, 30 HP

% of Rated Load	25	50	75	100	125	150	S.F.
Power Factor	47	69	77	84	84	83	84
Efficiency	90.9	93.9	94.4	94	92.9	92.5	93.4
Speed	1794	1786	1780	1773	1764	1754	1768
Line amperes	13.3	17.6	23.4	28.5	35.9	43.6	32.9

Performance Graph at 575V, 60Hz, 30.0HP Typical performance - Not guaranteed values

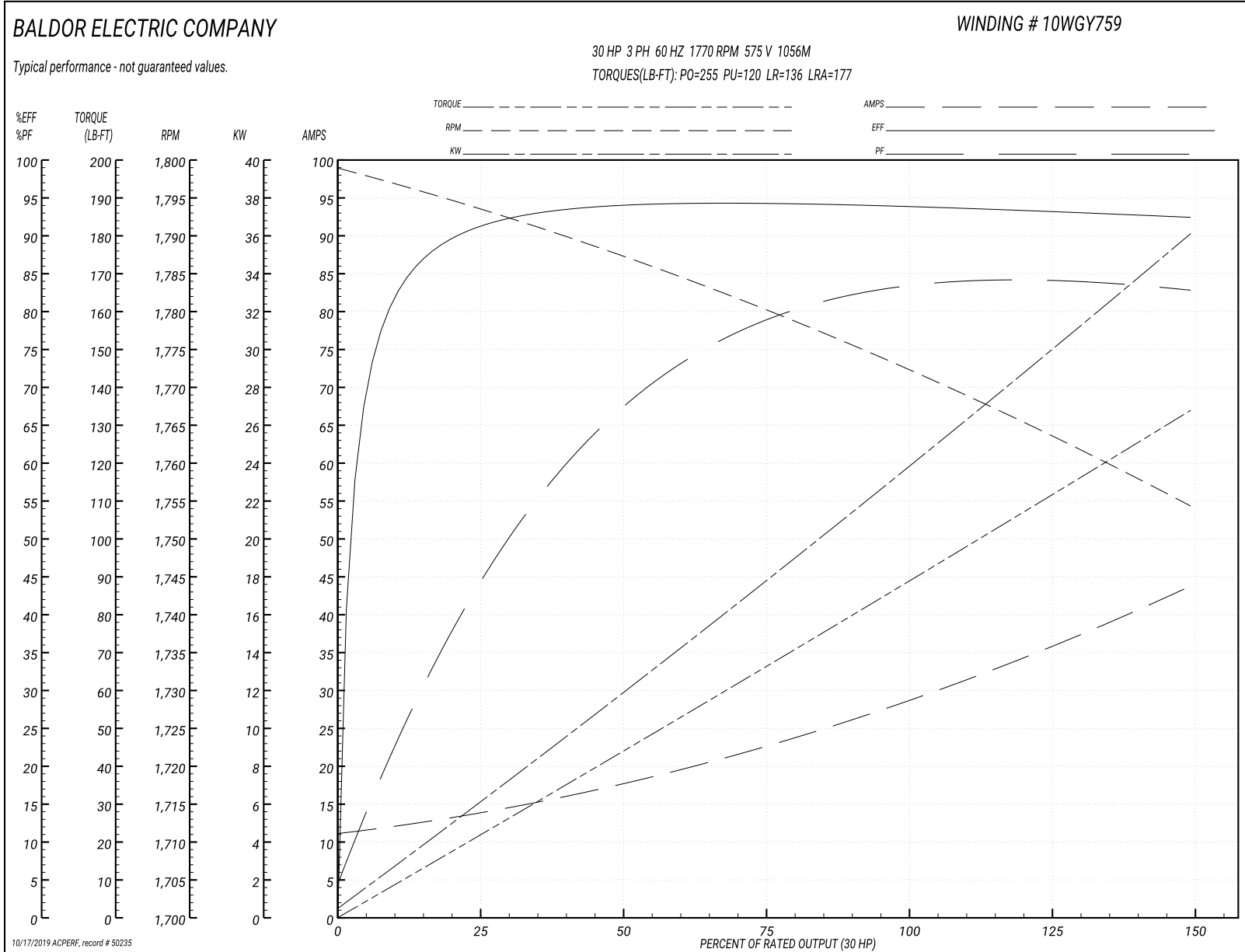

10LYH279

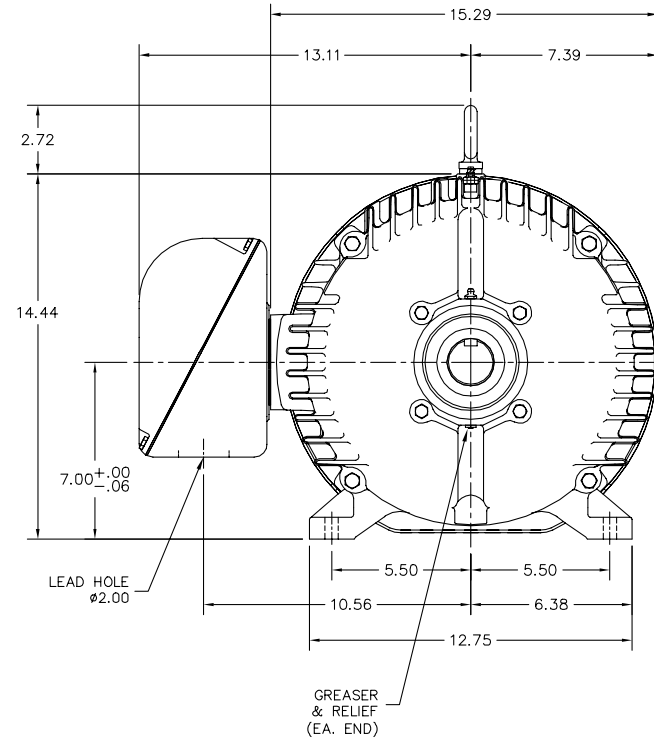
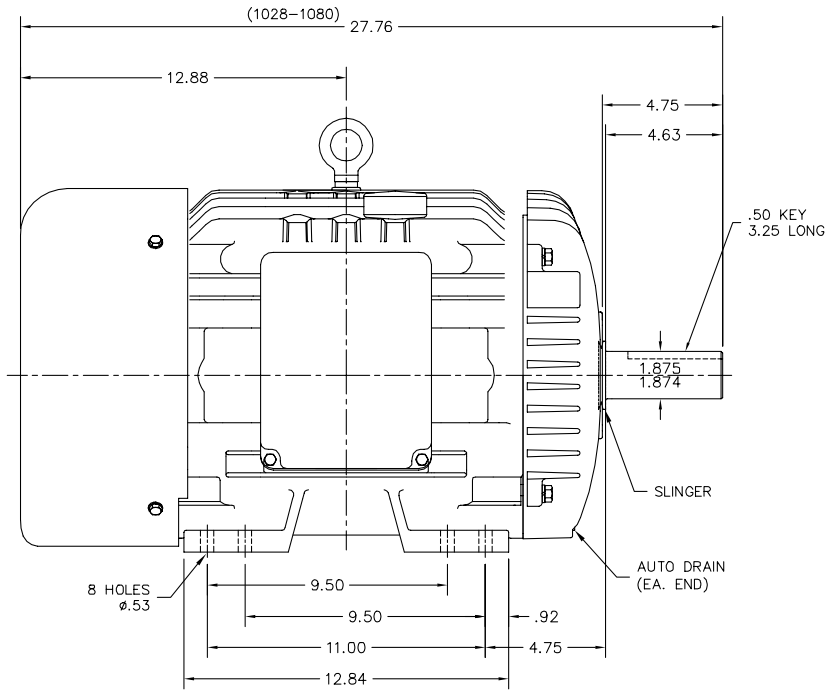

PU BRG RETAINER DETAIL

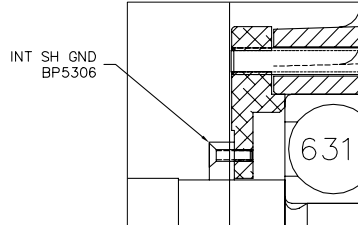

CUSTOMER IS RESPONSIBLE FOR DETERMINING THAT BALDOR'S PRODUCT WILL PERFORM SUITABLY IN THE INTENDED APPLICATION.

REV. DESC: REMOVE LOCKNUT	VERSION: 04	TDR: 000000952817
REV. LTR: D	REVISED: 03:37:46 11/10/2015	BY: ENMARSO
FILE: \AAA\00174\262		
MTL: -		

BALDOR
 HORZ TEFC 284-6T W/INT SH GND
 SH 1 of 1

10LYH279

CD0006

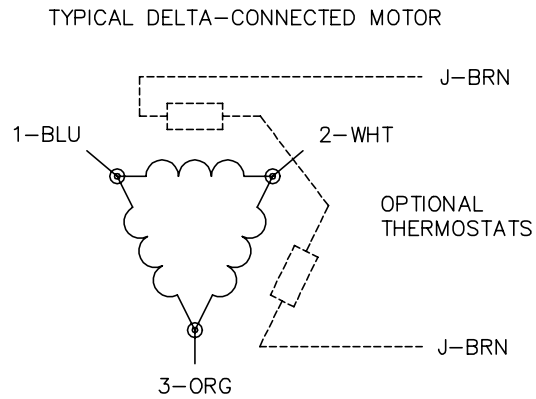
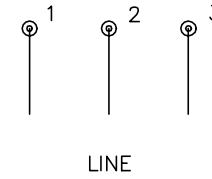
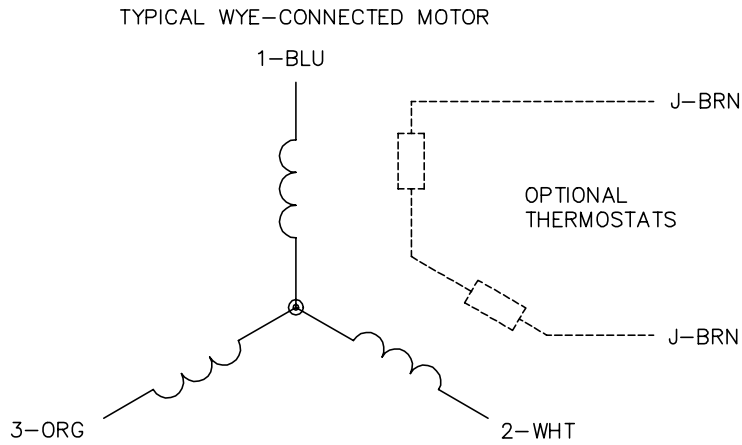

NOTES:

1. THREE LEAD MOTOR MAY BE EITHER WYE CONNECTED OR DELTA CONNECTED.
2. INTERCHANGE ANY TWO LINE LEADS TO REVERSE ROTATION.
3. OPTIONAL THERMOSTATS ARE PROVIDED WHEN SPECIFIED.
4. ACTUAL NUMBER OF INTERNAL PARALLEL CIRCUITS MAY VARY.
5. LEAD COLORS ARE OPTIONAL. LEADS MUST BE NUMBERED AS SHOWN.

CD0006

REV. DESC: ADD CLASS CONN00000007		
REV. LTR: E	VERSION: 01	TDR: 000001099922
FILE: \AAA\00005\141	REVISED: 10:24:49 02/19/2019	BY: ENBRIRO
MTL: -		

BALDOR - RELIANCE®

3PH, SV, 3 LEADS, WYE OR DELTA CONNECTED

SH 1 of 1